

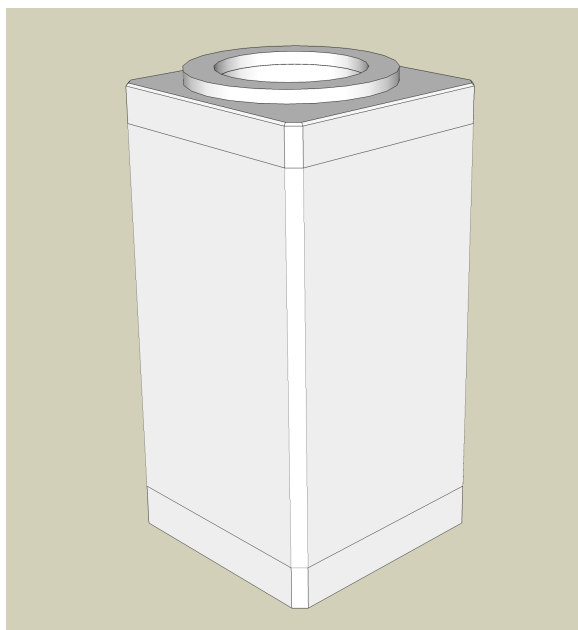

# MKK柵

## 製品CADデータ



製品名	サイズ	高さ
MKK柵	800	調整リングH50,100
		床板
		直壁H300~1500
		底板H150,200,250

- ・雨水貯留槽の管理柵として使用可能
- ・直壁の高さを50mmピッチで自由に変更可能



松阪興産株式会社

MATSUSAKA  
KOSAN

2023.1版





調整リング φ840×50

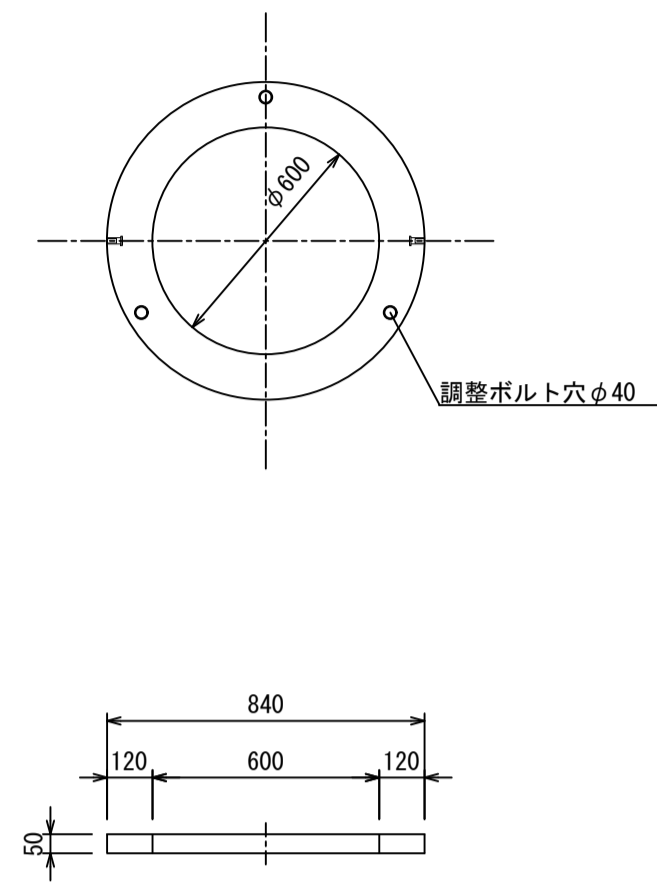

調整リング φ840×100

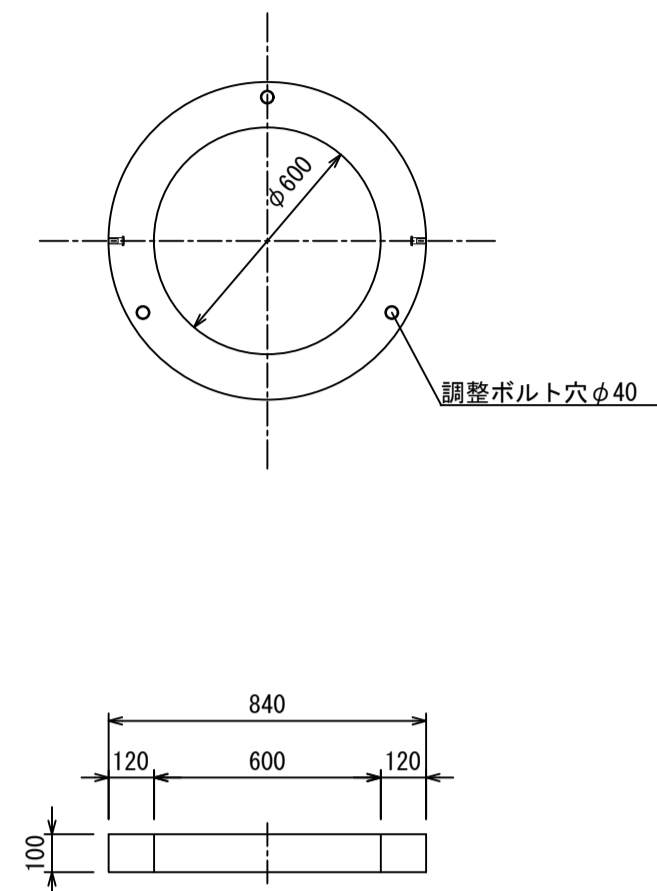

頂版 □800×H170

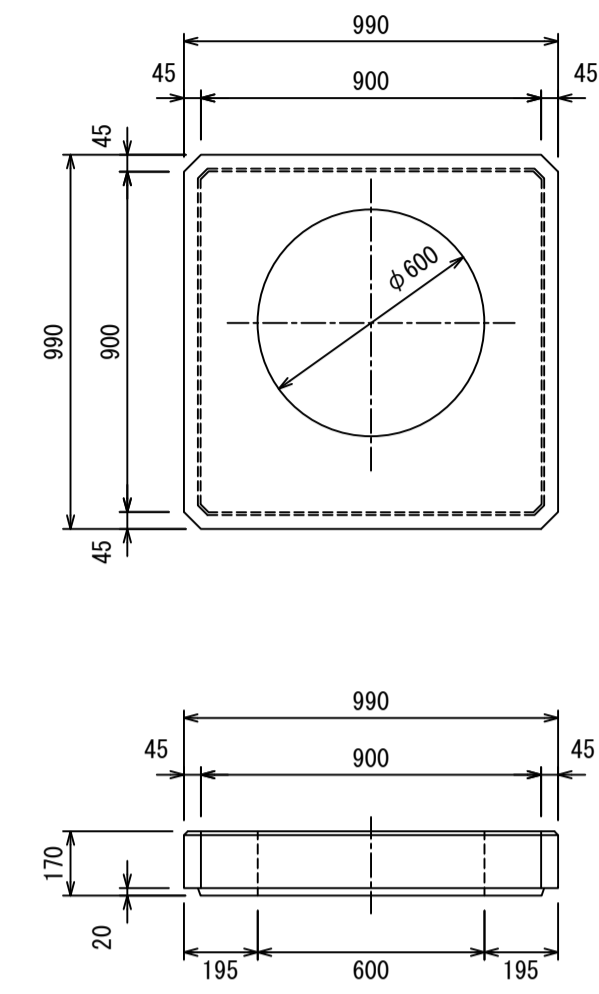

側塊 □800×H300

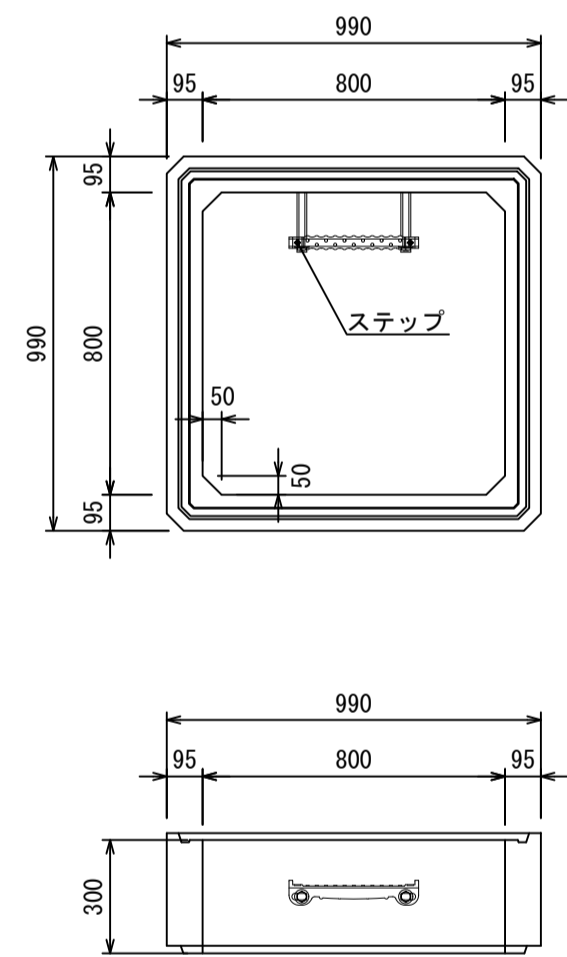

側塊 □800×H400

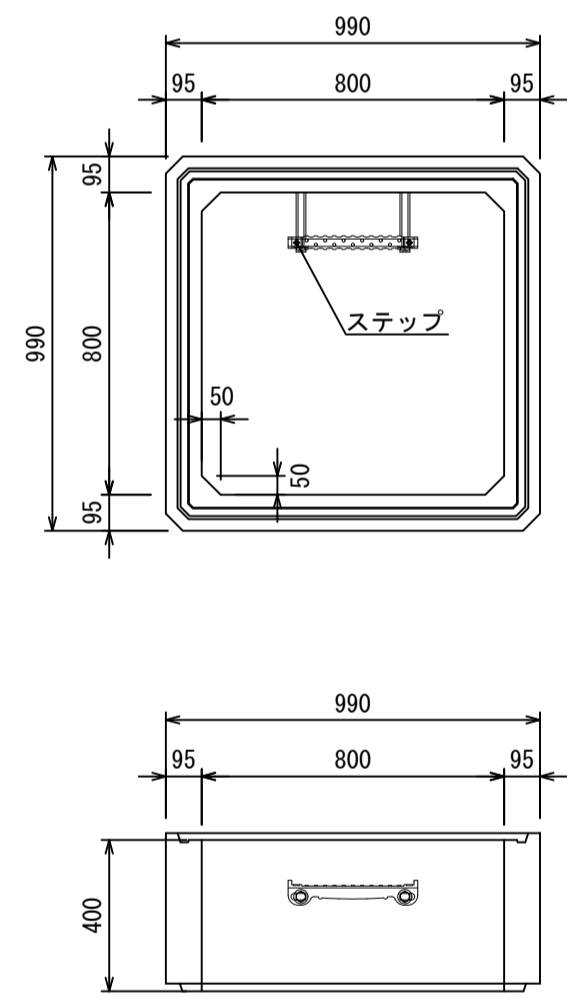

側塊 □800×H500

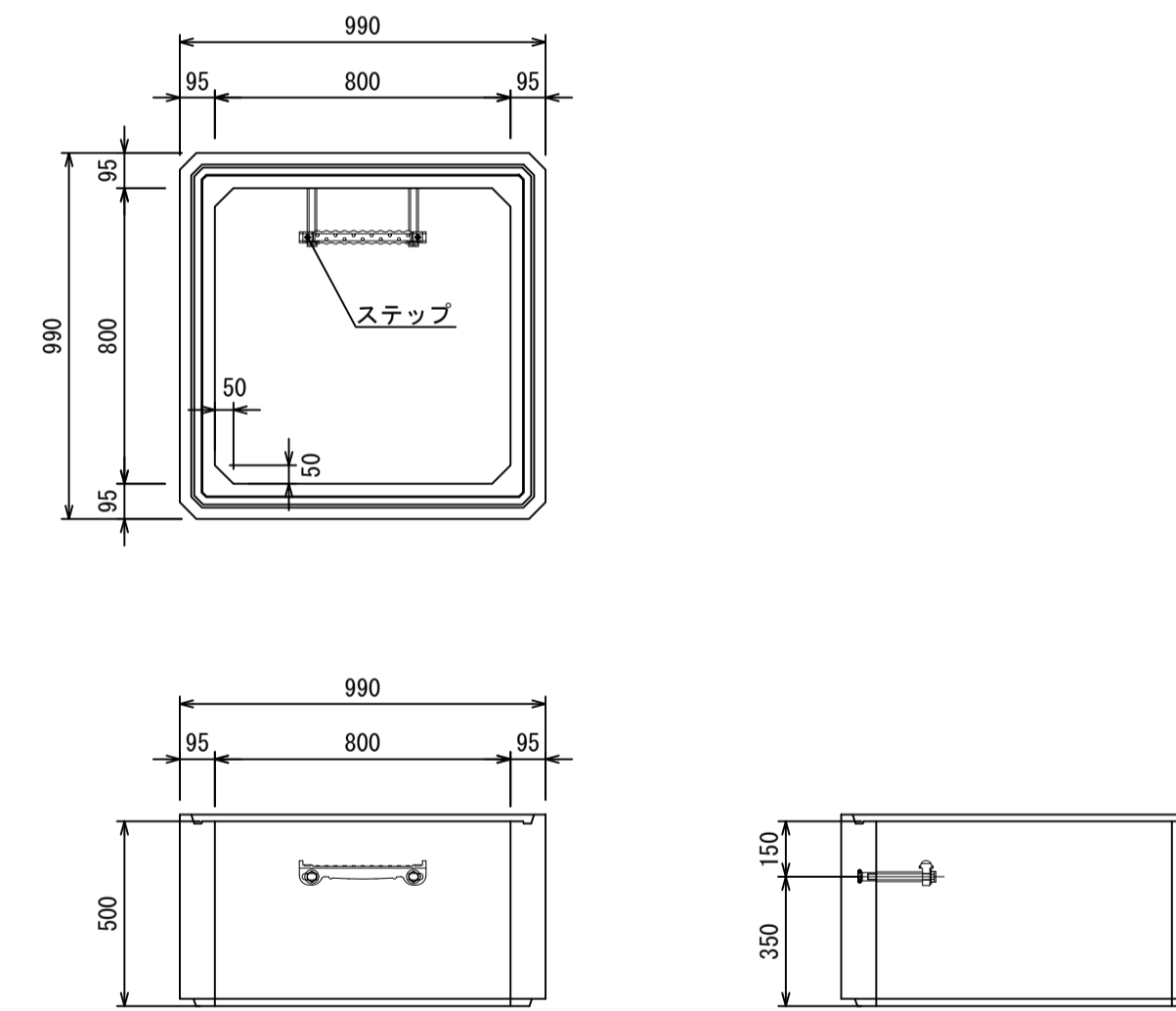

図面名称

MKK柵製品図(1)

縮尺

A1 1/20

2023.01版

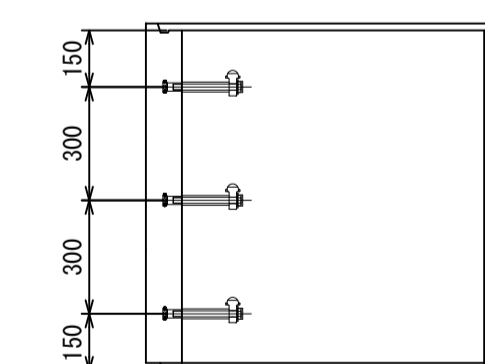
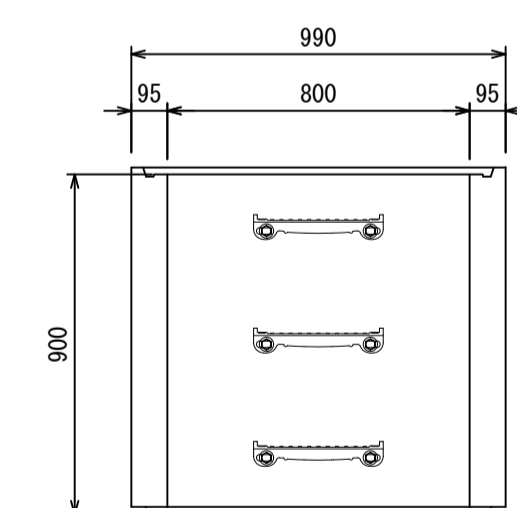
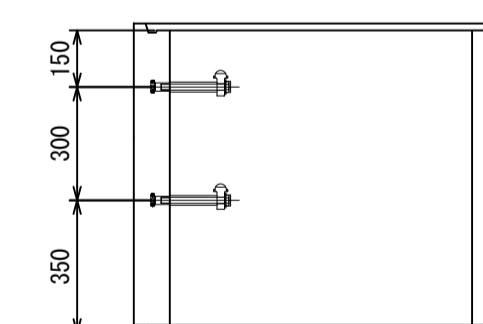
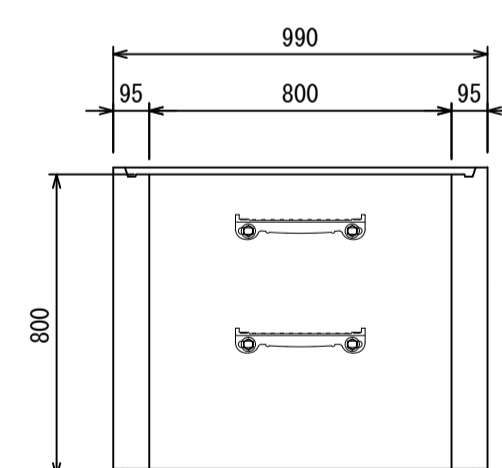
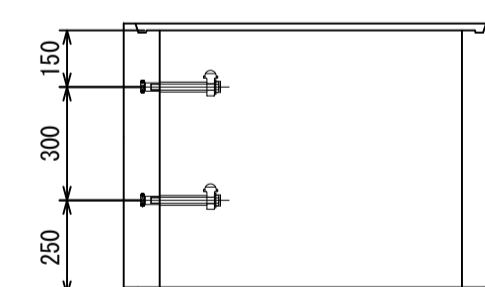
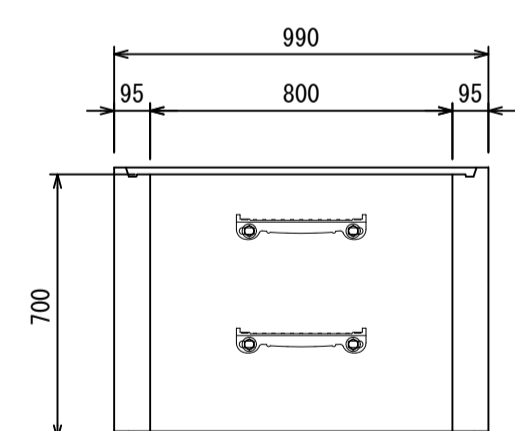
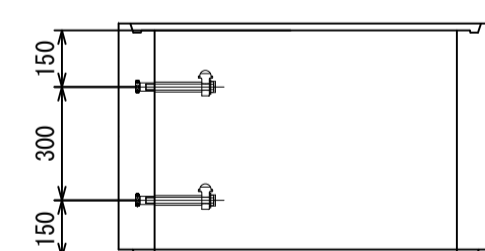
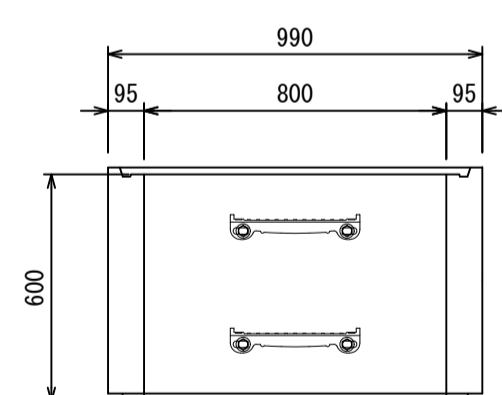
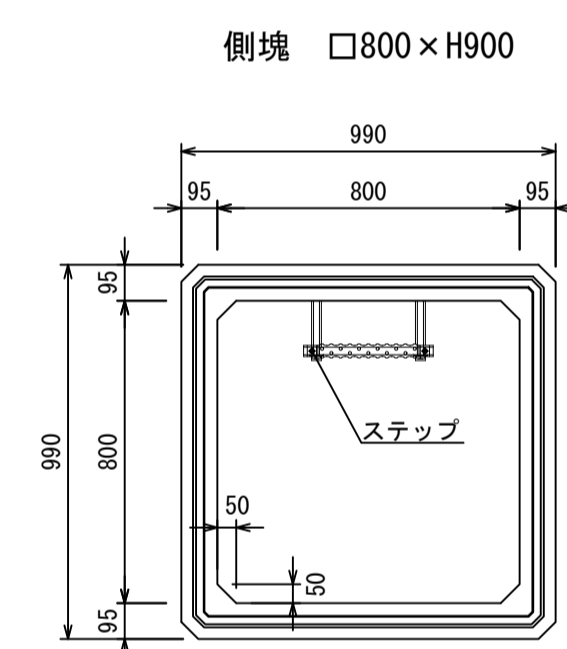
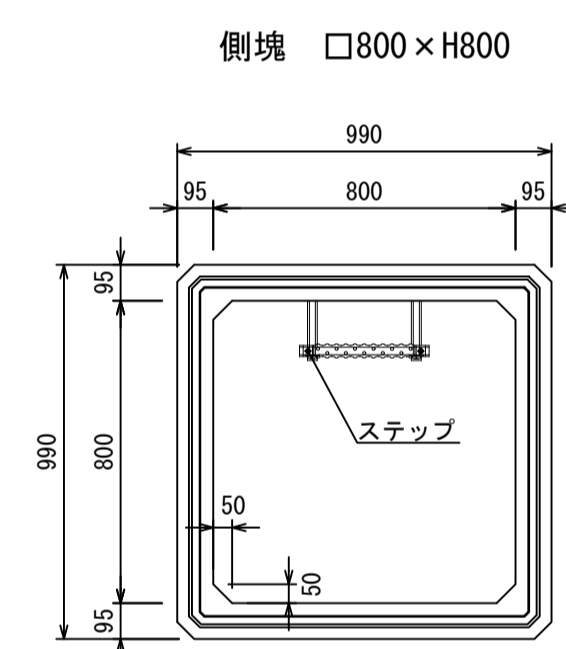
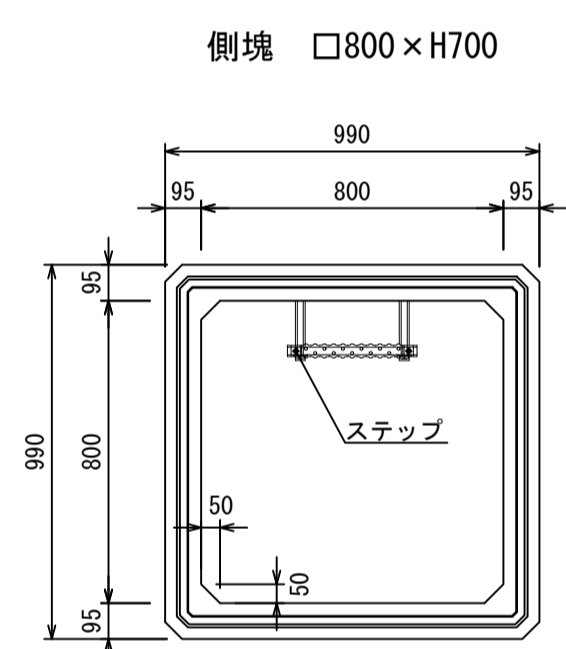
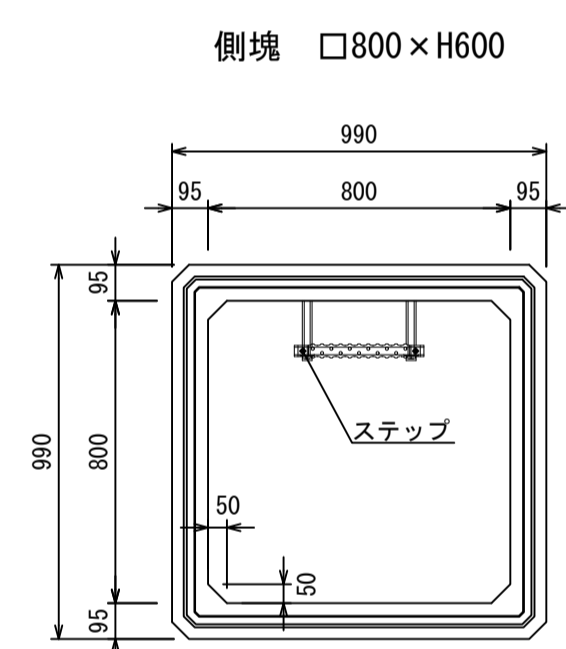

図面名称	MKK樹製品図(2)	
縮尺	A1 1/20	2023.01版

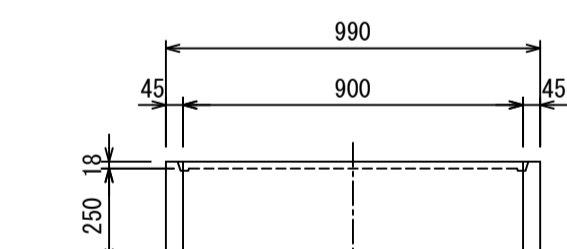
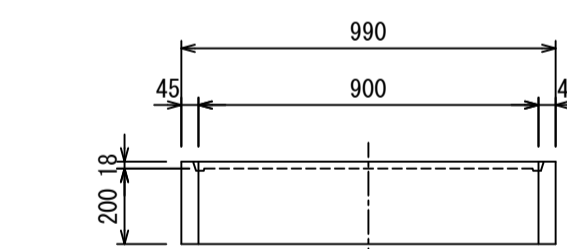
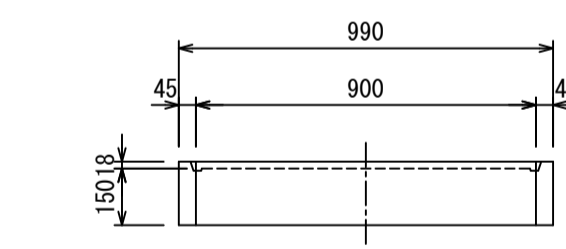
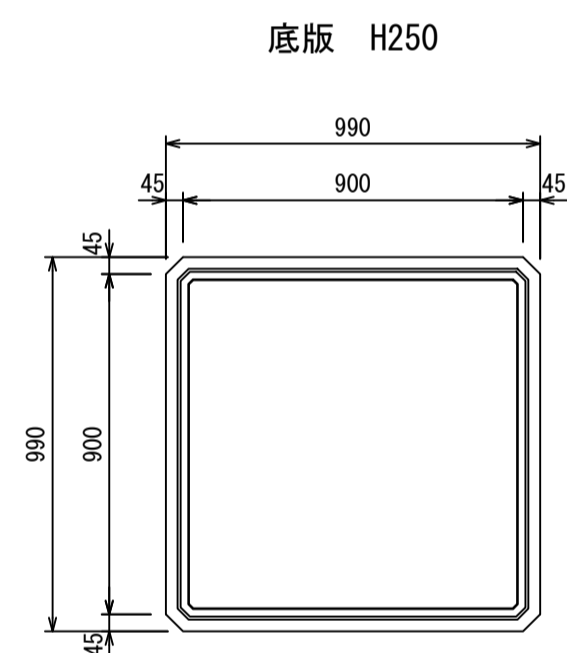
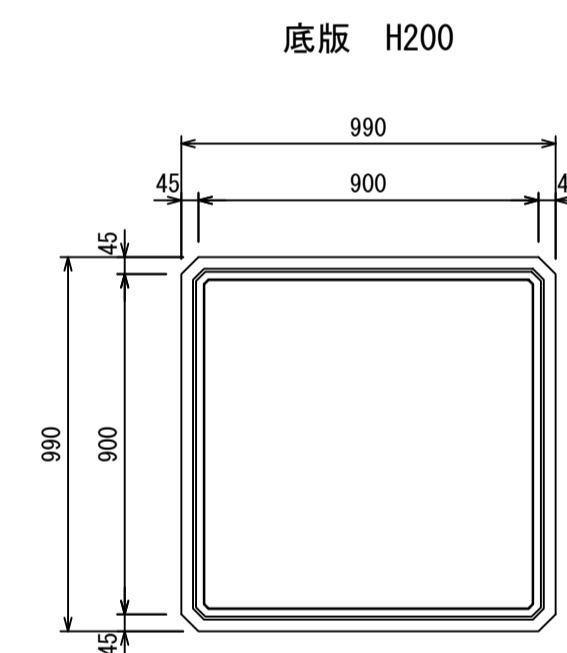
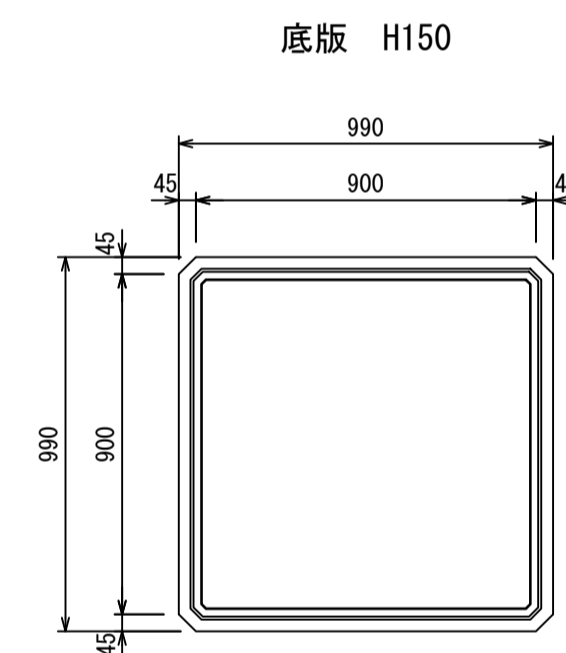
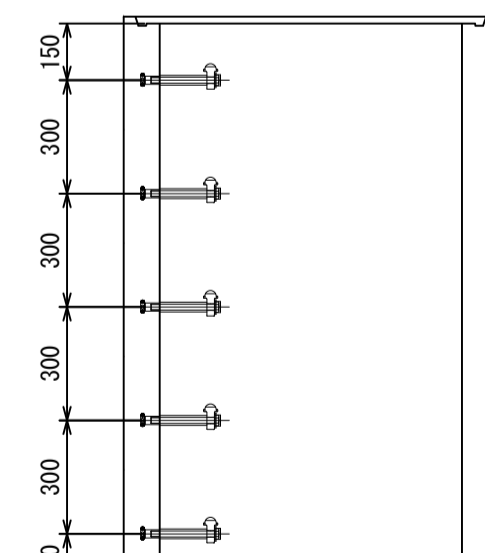
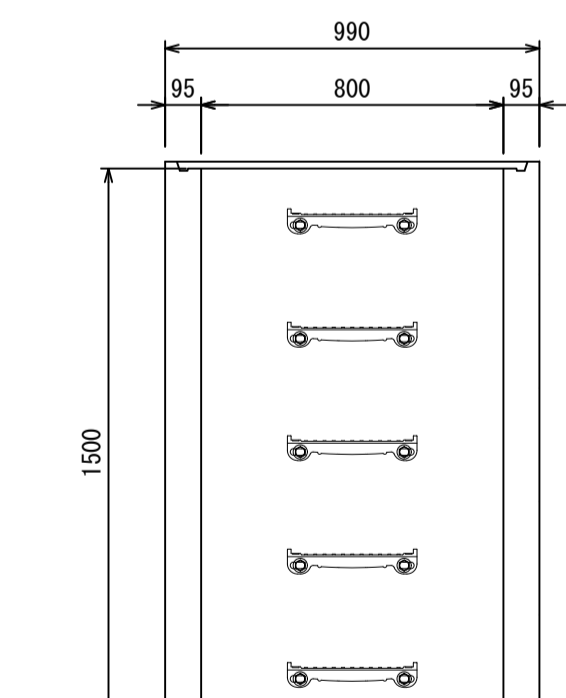
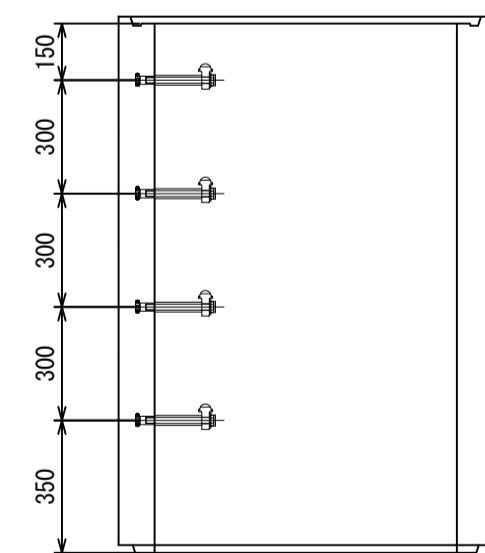
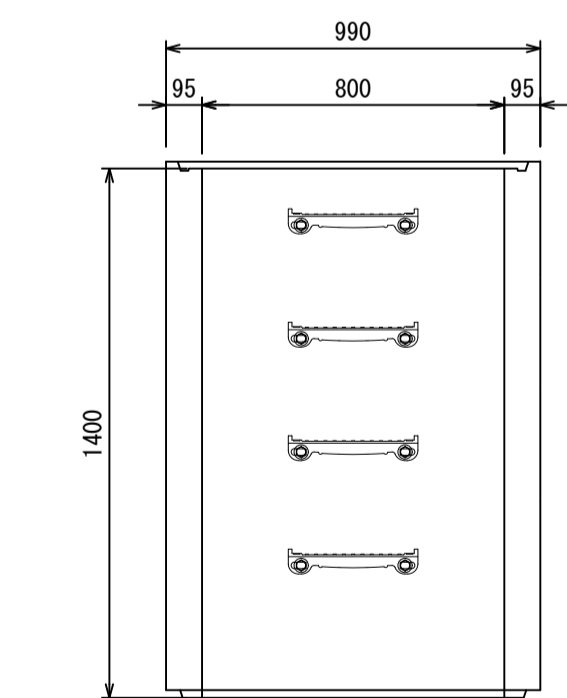
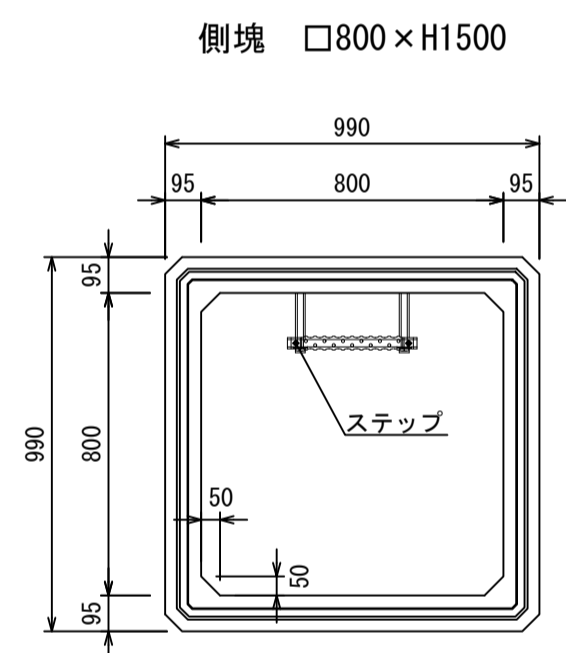
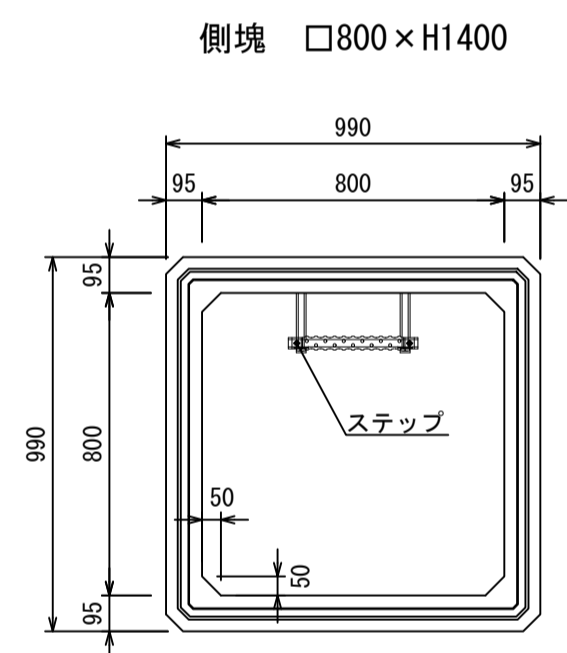
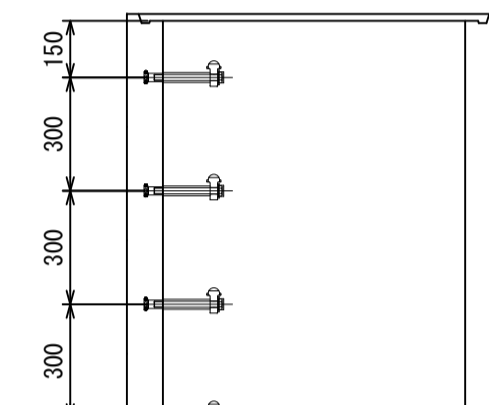
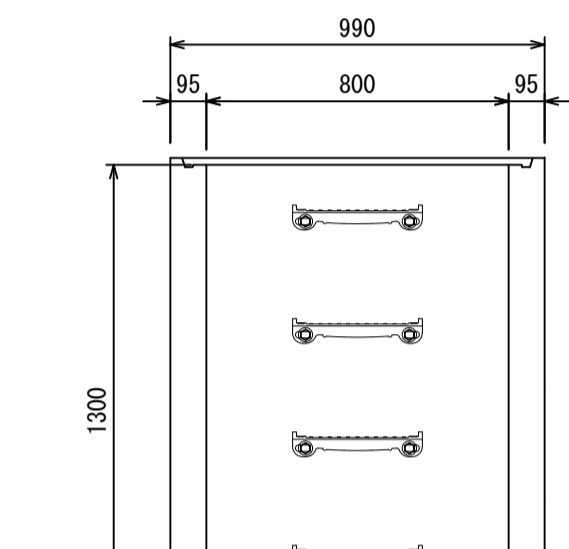
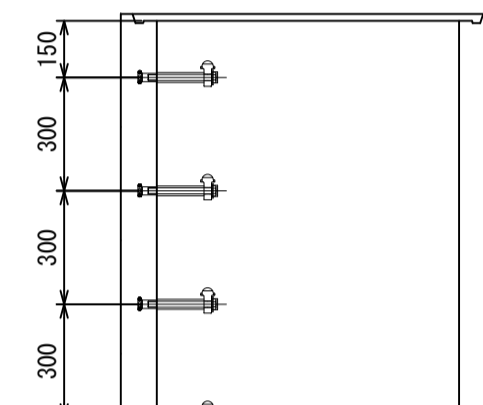
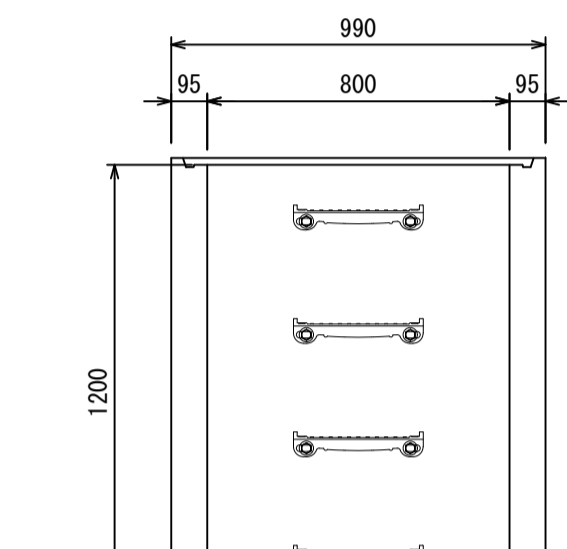
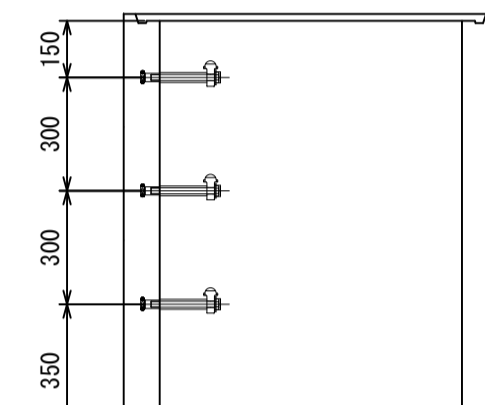
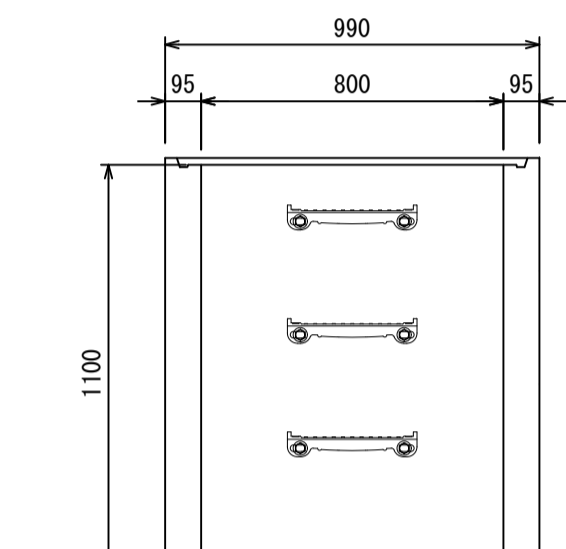
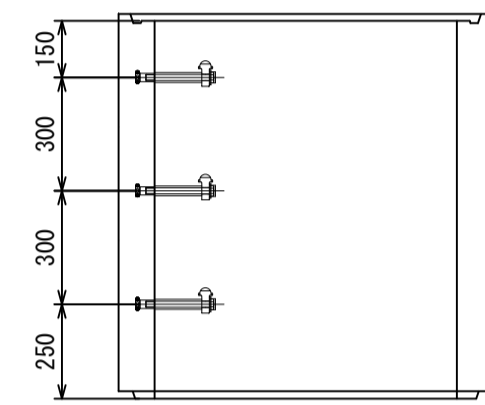
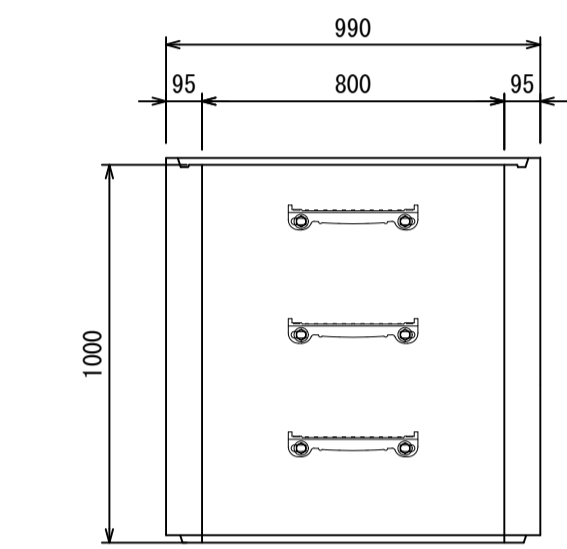
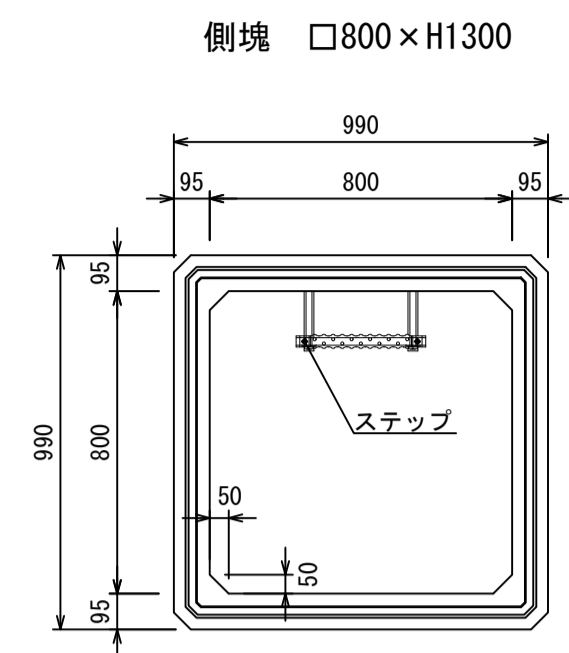
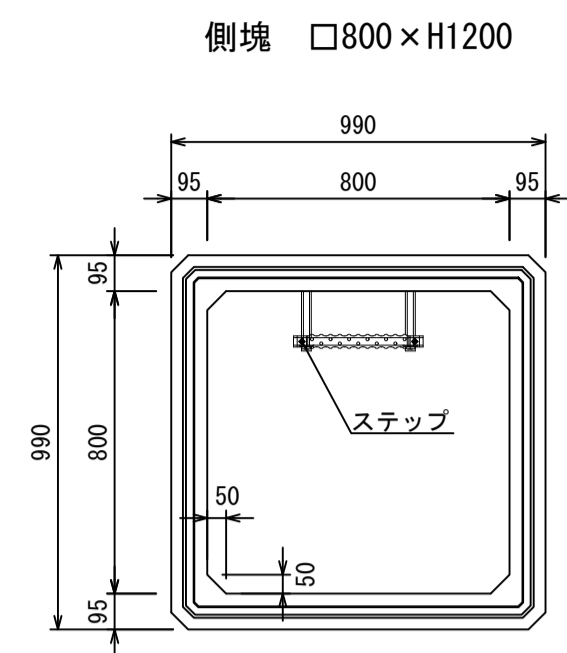
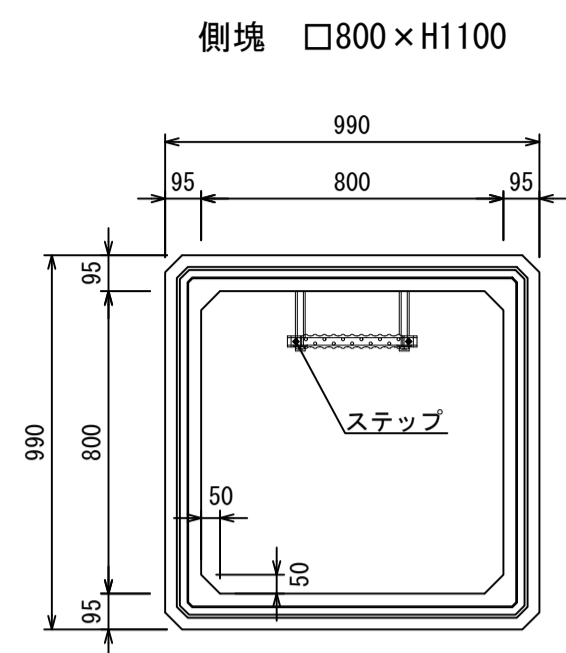
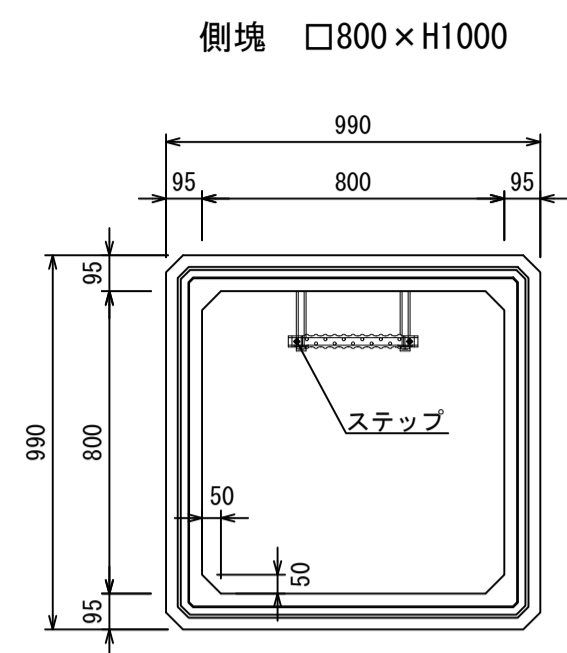

図面名称	MKK樹脂製品図(3)	
縮尺	A1 1/20	2023.01版