

# 上ぶた式U形側溝

## ■L=0.6m

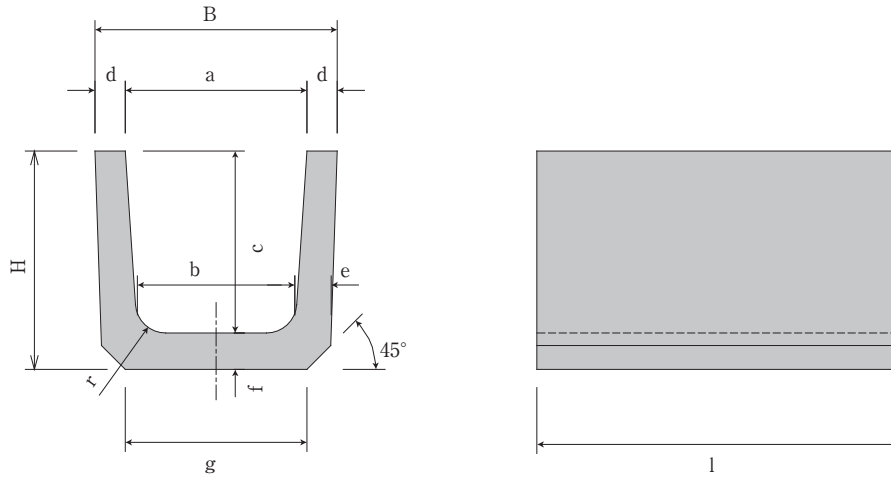

## ■寸法重量表

種類	呼び	参考重量 (kg)	寸法 (mm)										
			a	b	c	d	e	f	g	r	l	B	H
1種	150	24	150	140	150	30	35	35	160	30	600	210	185
	180	34	180	170	180	35	40	40	190	50		250	220
	240	55	240	220	240	45	50	50	240			330	290
	300A	70	300	260	240	50	60	60	300			400	300
	300B	79	300	260	300	50	60	60	300			400	360
	300C	92	300	260	360	50	60	65	300			400	425
	360A	90	360	310	300	50	65	65	360			460	365
	360B	100	360	310	360	50	65	65	360			460	425
	450	134	450	400	450	55	70	70	430			560	520
	600	209	600	540	600	70	80	80	600	70		740	680



## ■L=1.0m

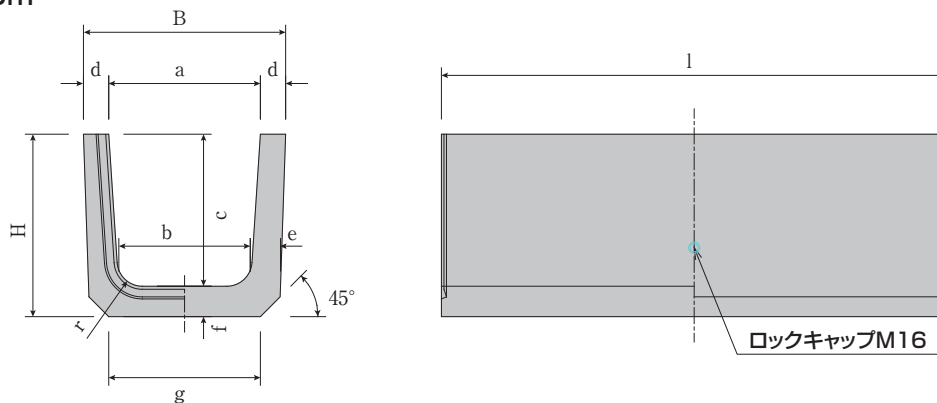

## ■寸法重量表

種類	呼び	参考重量 (kg)	寸法 (mm)										
			a	b	c	d	e	f	g	r	l	B	H
1種	240	92	240	220	240	45	50	50	240	50	1000	330	290
	300B	132	300	260	300	50	60	60	300	50	1000	400	360
	360B	166	360	310	360	50	65	65	360	50	1000	460	425
	450	223	450	400	450	55	70	70	430	70	1000	560	520
	600	348	600	540	600	70	80	80	600	70	1000	740	680



# 上ぶた式U形側溝・蓋

## ■L=2.0m

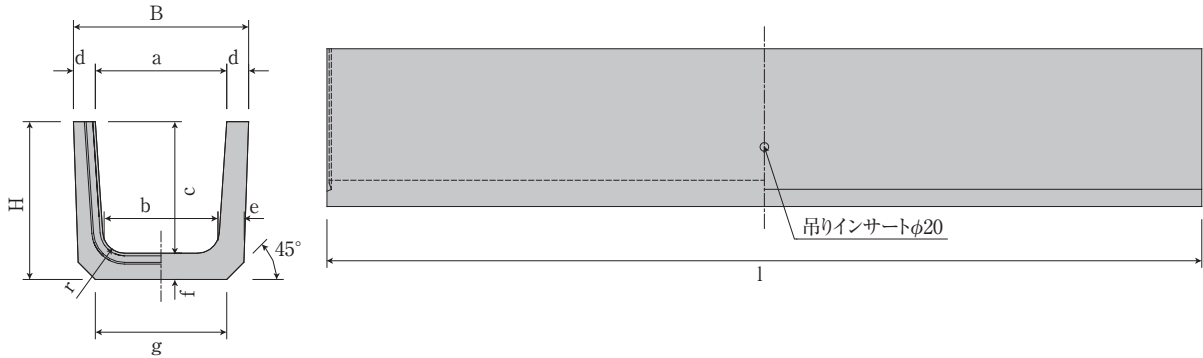

## ■寸法重量表

種類	呼び	参考重量 (kg)	寸法 (mm)										
			a	b	c	d	e	f	g	r	l	B	H
1種	240	184	240	220	240	45	50	50	240	50	2000	330	290
	300B	264	300	260	300	50	60	60	300			400	360

## ■1種

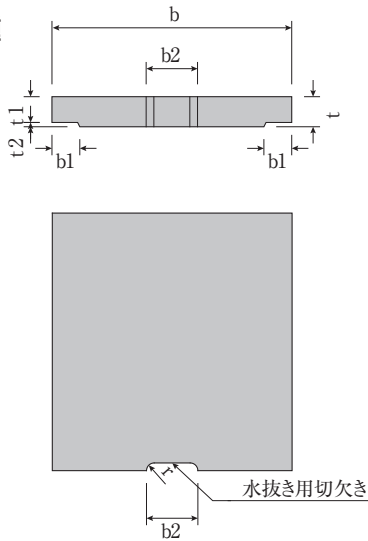

## ■2種

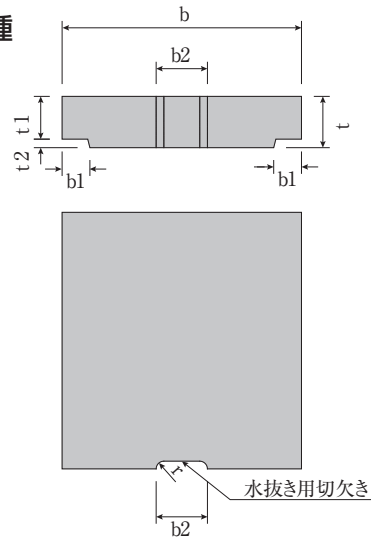

## ■寸法重量表

種類	呼び	参考重量 (kg)	寸法 (mm)							
			b	b1	t	t1	t2	l	r	b2
1種	150	10	210	35	35	30	5	600	15	75
	180	14	250	40	40	35	5	600	15	75
	240	20	330	50	45	40	5	600	15	90
	300	32	400	55	60	50	10	600	15	100
	360	41	460	55	65	55	10	600	18	120
	450	54	560	60	70	60	10	600	18	120
	600	77	740	75	75	65	10	600	18	150
2種	150	26	210	35	90	80	10	600	15	75
	180	31	250	40	90	80	10	600	15	75
	240	44	330	50	100	85	15	600	15	90
	300	54	400	55	100	85	15	600	15	100
	360	63	460	55	100	85	15	600	18	120
	450	92	560	60	120	100	20	600	18	120
600	153	740	75	150	130	20	600	18	150	

